



**PRESSES**  
MECHANICAL & HYDRAULIC

## *Gap Frame Presses*

*GZ & GL Series*

40T - 400T



Safeties conform to:  
CE (EN-16092 : 2018)  
OSHA 1910.217  
CSA-Z142  
NR-12

ISO 9001:2015  
ISO 14001:2015  
OHSAS 18001 :2007

## **High Performance Sheet Metal Working**

**Rigidity • Precision • Reliability**



# ISGEC RHINO - GAP FRAME PRESSES

RIGIDITY • PRECISION • RELIABILITY

## Rigidity

- Frame fabricated from tested steel plates and stress relieved to ensure uniform stress distribution, better stability and fatigue free long life of the frame.
- Finite Element Analysis software used to verify fatigue life of stress relieved Press structure and to enable maximum rigidity.
- Stronger and symmetric frame having 10% less stress with reinforcement on both sides.
- High rigidity of frame reduces angular deflection thereby maintaining alignment of top and bottom dies. It increases die life and produces better quality stamped parts.

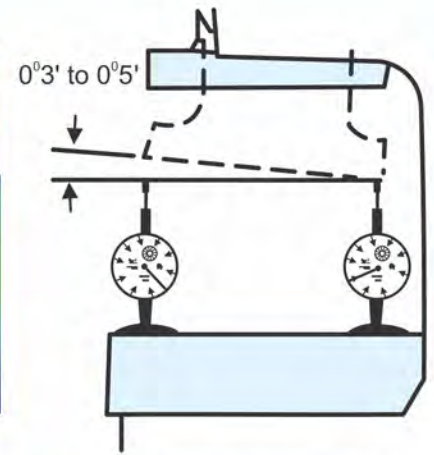
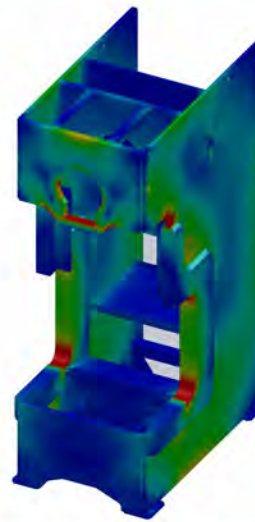

Measured at front and rear of Slide under full balanced load on GZ-160

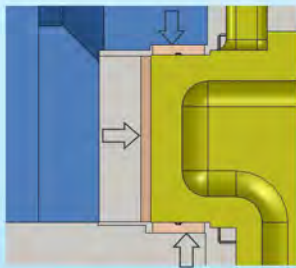

## Accurate Slide & Guide

- Extra long six point guides to ensure accurate slide guiding.
- Non Ferrous Liners.
- Accurately machined on CNC Machines.

## Precise and Vibration Free Transmission

### Crank Shaft

Forged from Normalized Alloy Carbon Steel, Ultrasonically Tested.

CAD analysis ensures elimination of stress concentrations and metal fatigues.

### Gear

Gears of drive train machined to precision grade, conforming to DIN Grade 7 or AGMA 10 and better, for smooth torque transmission and vibration free operation.

### Pinion

Forged Alloy Steel, Hardened & Tempered, Ultrasonically Tested, Accurately Machined and Ground.

### Connecting Rod

Steel Casted, Normalized and Ultrasonically Tested.

### Flywheel

Dynamically balanced Flywheel for long life of bearings.



## High Work Energy

- Highest Available Work Energy in its Class per Stroke



## Pneumatic Clutch and Brake

- Pneumatically operated Clutch and Brake for easy maintenance and service.
- Clutch & Brake controlled by Dual Solenoid Valve.
- Wet Clutch provided on demand.

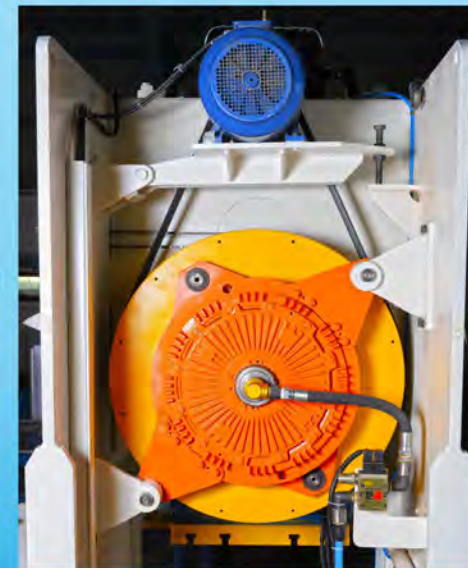

# FEATURES

## Hydraulic Overload Protection

Hydraulically operated fast acting Over Load protection mechanism mounted on slide for better performance thereby preventing damage to the Press and Dies



## Operator Control Station & Safety

- Programmable Logic Controller with user-friendly operator Interface has Operator Screens with Diagnostic features, improved through continuous feedback from Press users.
- Compliance with CE/OHSA Safety regulations provided on demand.
- Air Reservoir provided with Safety Valve, Pressure Switch and Drain Cock.



## Lubrication

- Automatic Grease Lubrication system lubricates Crank Shaft Bushes, Connecting Rod Bushes and Slide Guides.
- Oil Sump Lubrication for Main Gear Train for effective lubrication and heat dissipation.
- Lubrication is monitored through Progressive Lubrication Supply Line to give fault signals on HMI screen.

## Oil dipped Pitman Screw

- Slide adjustment threads oil dipped to reduce friction.
- Prevents jamming and increases life.



## Pneumatic Die Cushion

- Piston type Pneumatic Die Cushion ensures Long life. It is Maintenance friendly and easy to remove & install.



## Standard Accessories

- Pneumatic Counter Balance Cylinders
- Hydraulic Overload Protection
- Motorized Slide Adjustment
- Automatic Forced Lubrication
- Operator Panel with PLC & HMI
- Pneumatic Clutch & Brake
- Emergency Stop Buttons
- Electronic Shut Height Indicator
- Two Hand Push Button Station
- Production Counter
- Anti-Repeat Safety Device
- Rotary Cam Limit Switches
- Die Area Light
- Power Socket
- Photo Electric Guards

## Optional Accessories

- Pneumatic Die Cushion
- Wet Clutch
- Variable Speed through AC Inverter
- Tonnage Monitor
- Quick Die Change System
- Anti Vibration Mounts
- Auto Coil Feeding System
- Mis Feed Detection Socket
- Metallic Guards & Covers
- Air Outlet
- Mechanical Knock Out
- Safety Block



# ISGEC RHINO - LINK DRIVE GAP FRAME PRESSES (GZ & GL SERIES)

**Isgec Rhino Link Drive Presses** offer low speed in working zone resulting in increased metal flow time as the slide remains in the working position for more than 40% of the time compared to conventional drives. The approach & return speeds are higher, to maintain cycle time.

- **IMPROVED DIE LIFE**
- **BETTER QUALITY PARTS**
- **LOWER PART REJECTION**
- **HIGHER PRODUCTION RATE**

## 3D view of Link

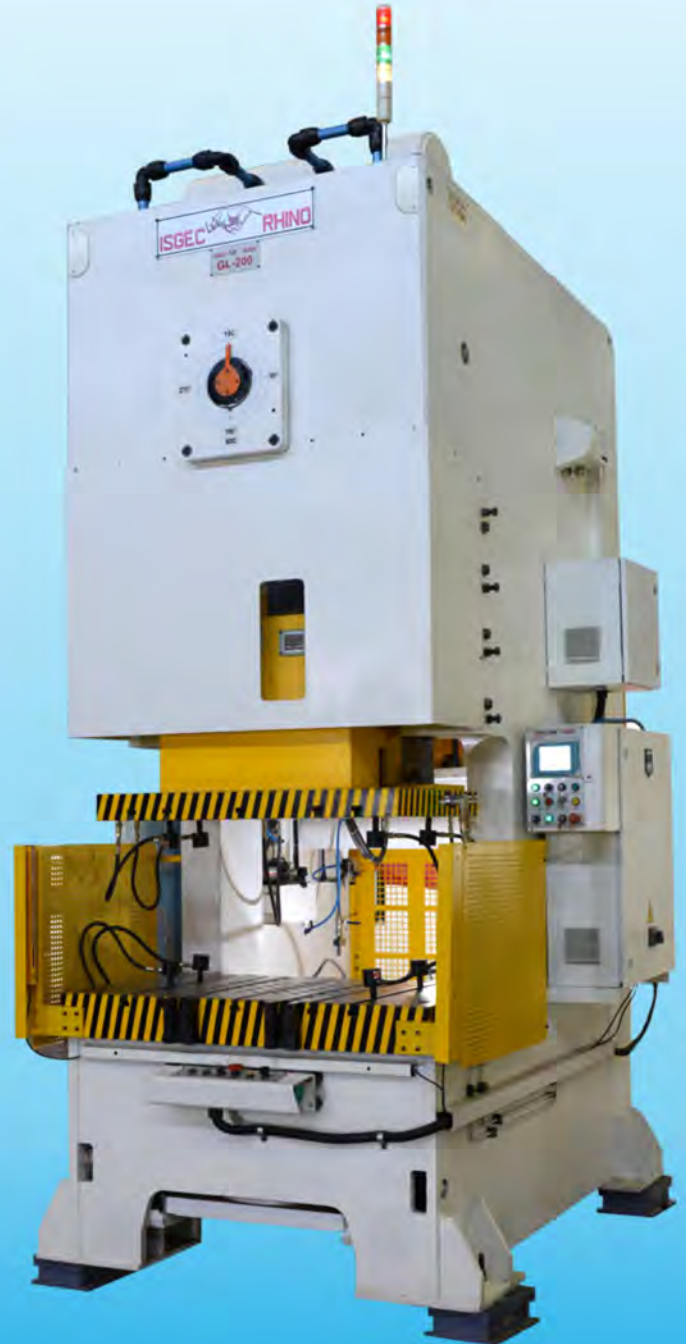
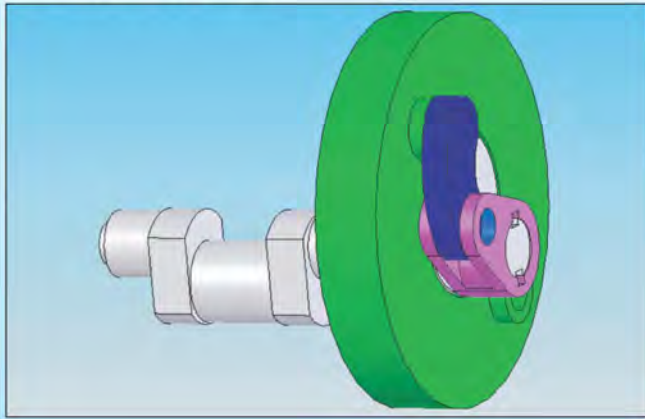

*The graph demonstrates the higher time available during working stroke in case of Isgec Link Drive Presses, compared to Conventional Drives.*

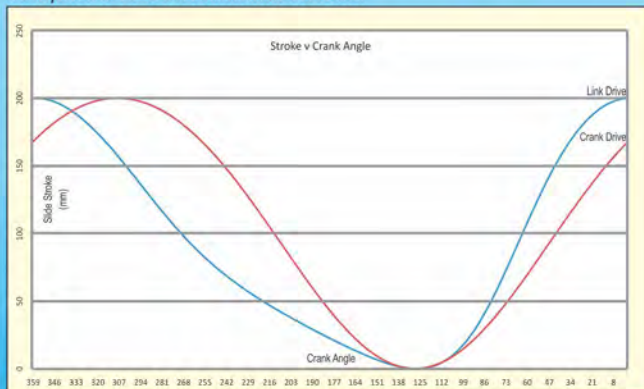

# SPECIFICATIONS

Tonnage	Unit	40	63	80	110	160	200	250	300	400
Models		GZ	GZ	GZ	GZ/GL	GZS/GZ/GL	GZS/GZ/GL	GZ/GL	GZ/GL	GZ
Maximum Capacity	kN	400	630	800	1100	1600	2000	2500	3000	4000
	US Ton	45	70	88	121	176	220	275	330	450
Rated distance	mm	4	4	4	6	6	6	6	8	8
	inch	0.16	0.16	0.16	0.24	0.24	0.24	0.24	0.31	0.31
Speed (Fixed)	spm	65	60	60	45	45	40	40	40	30
*Speed (Variable) <sup>^</sup>	spm	45-85	40-80	40-80	30-60	30-60	25-50	25-50	25-50	20-40
Stroke Length - Fixed	mm	70	120	150	180	200	200	250	250	250
	inch	2.7	4.7	5.9	7.1	7.9	7.9	9.8	9.8	9.8
Throat (t)	mm	225	250	310	355	400	425	475	475	475
	inch	8.8	9.8	12.2	14.0	15.7	16.7	18.7	18.7	18.7
Shut Height (s) Stroke Down Adjustment Up (SDAU)	mm	230	300	325	350	400/500/500	450/550/550	600	600	600
	inch	9	11.8	12.8	13.8	15.7/19.7/19.7	17.7/21.7/21.7	23.6	23.6	23.6
Slide Adjustment	mm	60	70	80	80	120	120	120	125	125
	inch	2.4	2.8	3.1	3.1	4.7	4.7	4.7	4.9	4.9
Slide Face (a x b)	mm	400 x 350	500 x 400	525 x 450	625 x 500	700 x 580	840 x 650	940 x 700	1100 x 800	1100 x 800
	inch	15.7 x 13.7	19.7 x 15.7	20.7 x 17.7	24.6 x 19.7	27.6 x 22.8	33.1 x 25.6	37 x 27.6	43.3 x 31.5	43.3 x 31.4
Bolster Size (c x d)	mm	800 x 450	900 x 500	1000 x 620	1150 x 710	1250 x 800	1450 x 850	1450 x 950	1450 x 950	1600 x 950
	inch	31.4 x 17.7	35.4 x 19.7	39.4 x 24.4	45.3 x 28	49.2 x 31.5	57.1 x 33.5	57.1 x 37.4	57.1 x 37.4	62.9 x 37.4
Bolster Thickness (f)	mm	90	90	100	115	140	160	160	160	190
	inch	3.5	3.5	3.9	4.5	5.5	6.3	6.3	6.3	7.4
Height of Bolster Surface from Floor (g). (without AVM pads)	mm	800	900	900	900	900	1000	1100	1200	1550
	inch	31.5	35.4	35.4	35.4	35.4	39.4	43.3	47.2	61
Main Motor Power	kW	3.7	5.5	7.5	11	15	15	18.5	22.5	37
*Die Cushion Capacity at 7kg/sq.cm.	kN	23	36	36	63	100	140	140	140	250
Die Cushion Stroke Length	mm	35	60	75	90	100	100	125	125	125
	inch	1.3	2.3	2.9	3.5	3.9	3.9	4.9	4.9	4.9
Die Cushion Pad Area	mm	300 x 230	350 x 300	450 x 310	500 x 450	600 x 450	600 x 560	600 x 560	600 x 560	750 x 700
	inch	11.8 x 9.1	13.8 x 11.8	17.7 x 12.2	19.7 x 17.7	23.6 x 17.7	23.6 x 22	23.6 x 22	23.6 x 22	29.5 x 27.5
#Overall Dimensions (n x l x m)	mm	2650x1450x1400	2750x1600x1500	3400x1800x1550	3400x2100x1650	3700x2300x1750	4150x2400x1950	4460x2600x1950	4850x2600x1900	6000x2800x2200
	inch	104.3x57x55.1	108.2x62.9x59	133.8x70.8x61	133.8x82.6x64.9	145.6x90.5x68.8	163.3x94.4x76.7	175.5x102.3x76.7	190.9x102.3x74.8	236.2x110.2x86.6

GZ & GZS: Standard Presses. GL: Link Drive Press.

\* Optional at extra cost.

<sup>^</sup> Single stroke working is recommended up to mid SPM only.

# Overall Dimensions of GL Series are slightly different.

- Dimensions given in inches are approximate.

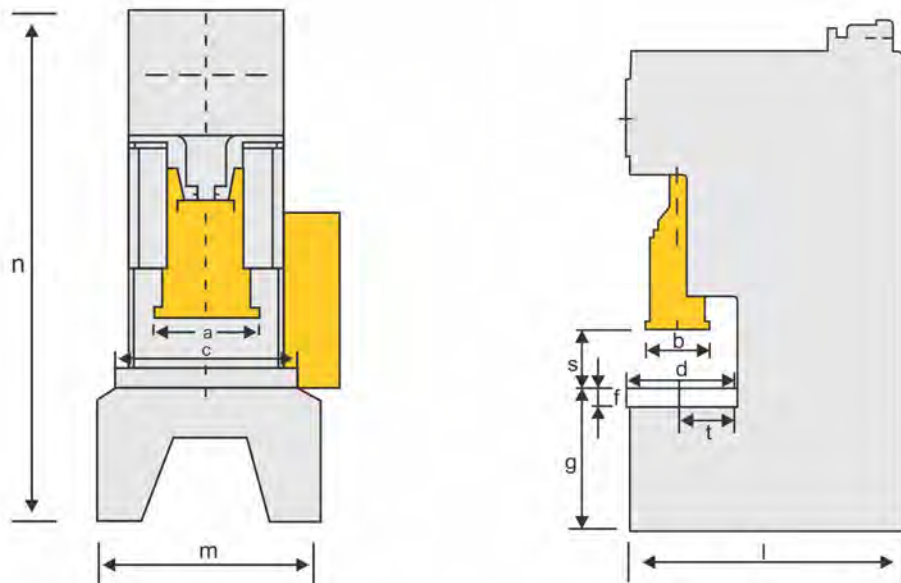

# AFTER SALES SERVICE NETWORK

AHMEDABAD • BAWAL • BANGALORE • CHENNAI • DELHI  
GURGAON • KOLKATA • MUMBAI • NOIDA • PUNE • YAMUNANAGAR



A battery of Presses (40 T to 300 T Capacity) supplied to MUSCO, India for production of components for Tata Motors.

## Wide Range of Presses

Servo Presses • Transfer Presses • Progressive Presses • High Speed Presses • Hot Stamping & Hot Forming Hydraulic Presses  
Standard Straight Sided Mechanical & Hydraulic Presses • Blanking Lines • Tandem Press Lines - Mechanical & Hydraulic  
Cold Forging Presses • Tryout & Die Spotting Presses • Gap Frame & Ring Frame Power Presses • Special Purpose Presses



[www.isgrec.com](http://www.isgrec.com)



**Plant** : Plot No. 123, Sector - 6, HSIIDC Growth Centre, Bawal - 123 501 (Haryana) India  
Tel.: +91-8930234025  
E-mail: [smpbawal@isgrec.com](mailto:smpbawal@isgrec.com), [brijender@isgrec.com](mailto:brijender@isgrec.com)

**Sales Office:** **Gurgaon**  
Unit No. 0403, (4th Floor), Emerald Plaza, Sector-65, Gurugram - 122 102 (Haryana) India  
Tel.: +91-405 2749 E-mail: [smp.north@isgrec.com](mailto:smp.north@isgrec.com)

**Regional Offices:** **Mumbai**  
Great Social Building, Sir Phirozshah Mehta Road, Fort, Mumbai 400 001, India  
Tel.: +91-22-22 66 23 74 Email: [presses.wr@isgrec.com](mailto:presses.wr@isgrec.com)

**Chennai**  
Grace Building, (3rd Floor), No 25, Mc Nichols Road, Chetpet, Chennai 600 031, India  
Tel.: +91-44-28 36 13 75, 28 36 13 51 Email: [presses.sr@isgrec.com](mailto:presses.sr@isgrec.com)

**Kolkata**  
18, Main Road, Kalianiwas, Barrackpore, Kolkata 700 122, India  
Tel.: +91-98363 61411 E-mail: [presses.er@isgrec.com](mailto:presses.er@isgrec.com)

**Overseas Offices** : Ontario, Canada • Jakarta, Indonesia

**Sales Representatives** : Brazil • China • France • Germany • Hungary • Indonesia • Italy • Japan • Malaysia • Mexico • Poland  
Russia • South Africa • Spain • Thailand • Turkey • USA • Vietnam